

Recommended P.C.Board Layout
PCB Tolerance:±0.05(Top View)

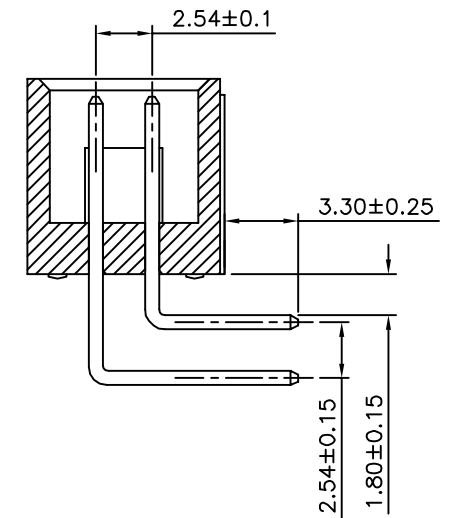
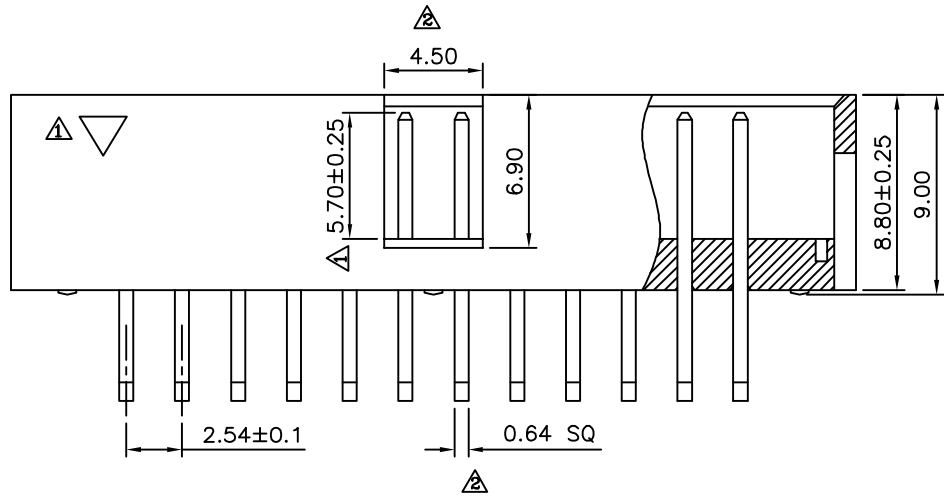
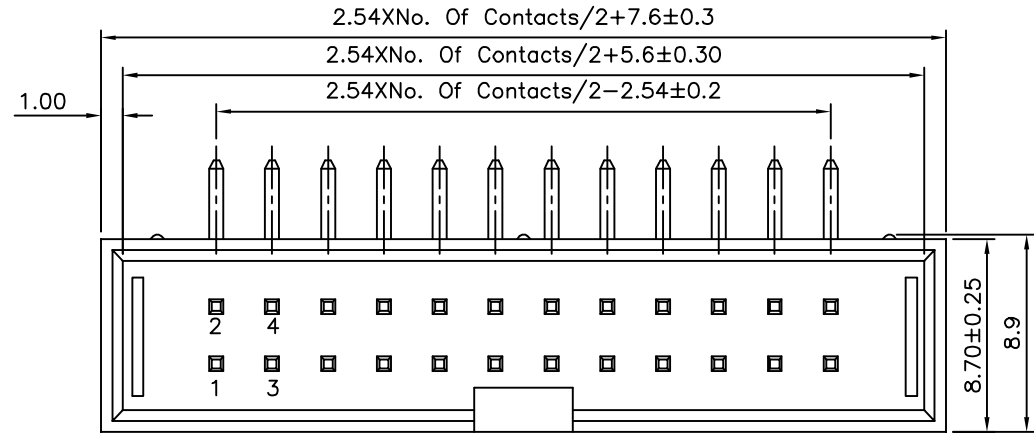

△ SPECIFICATION
 Current Rating:3 Amps
 Withstand Voltage:1000V AC
 Contact Resistance:20 Milliohms Max.
 Insulation Resistance:1000 Megaohms Min.
 Operation Temperature:-40°C~+105°C
 △Insulator:PBT(UL94V-0),Gray
 Contact:Brass,Gold Flash Over Nickel
 RoHS Compliant

4UCON 元化興業股份有限公司
 4UCON TECHNOLOGY INC.

DRAWING No.		APPROVED BY		UNLESS OTHERWISE SPECIFIED TOLERANCES ARE △ X. ±0.25 X.* ±2° .X ±0.20 .X* ±1.5° .XX ±0.15 .XX* ±1° .XXX ±0.10 .XXX* ±0.5°	NO. REV.	REVISIONS	CHK	DATE			
00007		MEI	A3						Modify Data	HZF	03/18/2016
SCALE	NONE	HZF	A2						Modify Data	HZF	04/17/2015
REV.	A3	CYP	A1	Modify Data	HZF	08/08/2014					
			A0	NEW RELEASE	HZF	12/18/2010					

UNIT	mm
REV.	A3