

△△ SPECIFICATION
 Current Rating:1.5 Amps
 Withstand Voltage:500V AC
 Contact Resistance:20 Milliohms Max.
 Insulation Resistance:1000 Megaohms Min.
 Operation Temperature Range:-40°C~+105°C
 Insulator:PA6T(UL94V-0),Black
 Contact:Brass,Gold Plated Over Nickel
 RoHS Compliant

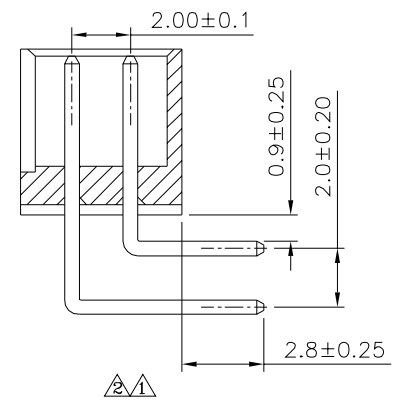
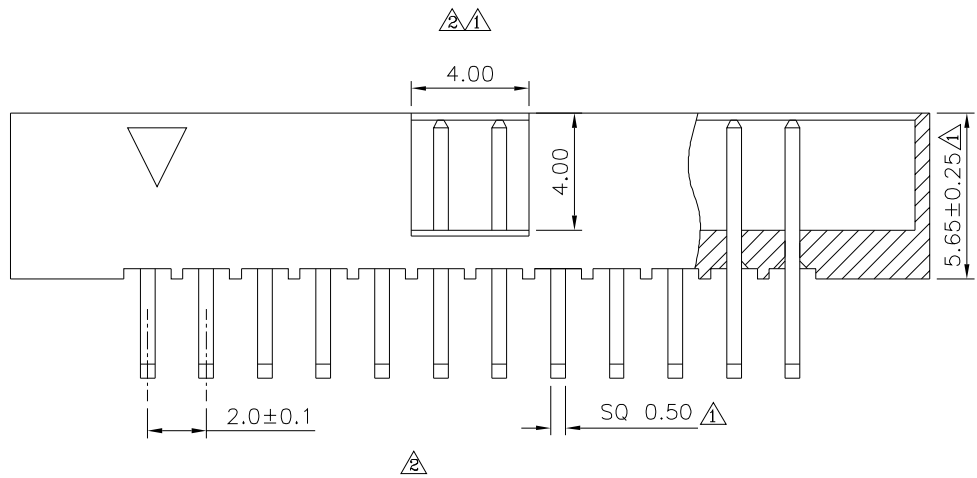
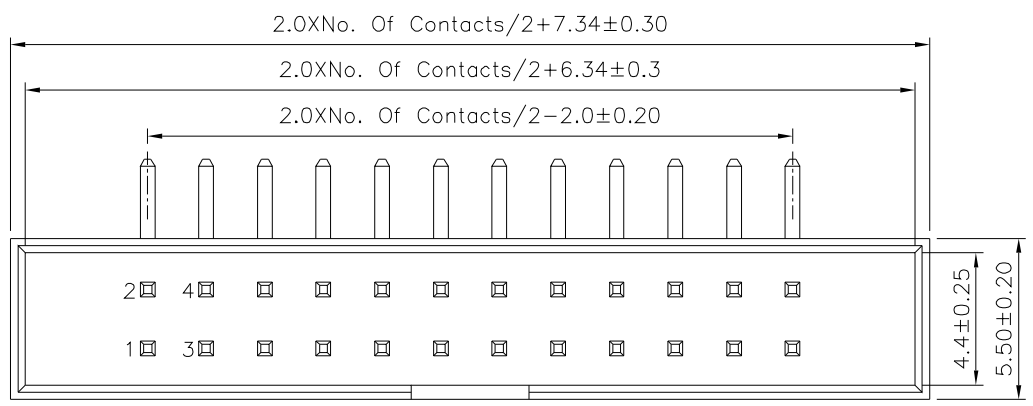

4UCON 元化興業股份有限公司
 4UCON TECHNOLOGY INC.

DRAWING No. 03480

APPROVED BY MEI
 CHECKED BY HZF
 DRAWING BY CYP

UNLESS OTHERWISE SPECIFIED TOLERANCES ARE
 X. ±0.25 X.* ±2°
 .X ±0.20 .X* ±1.5°
 .XX ±0.15 .XX* ±1°
 .XXX ±0.10 .XXX* ±0.5°

UNIT mm

NO.	REV.	REVISIONS	CHK	DATE
△	A2	Modify Data	HZF	05/23/2018
△	A1	Modify Data	HZF	04/27/2016
△	A0	NEW RELEASE	HZF	08/10/2013

SCALE NONE

REV. A2

NO. REV. REVISIONS CHK DATE