

△ SPECIFICATION
 Current Rating: 1.5A Max.
 Voltage Rating: 150V AC Max.
 Operating Temperature: -40°C ~ +85°C
 Relative Humidity: 70% ± 10% RH
 Insulation Resistance: 500 Megaohms Min. Initial
 At 500V DC
 Contact Resistance: 20 Milliohms Max. Initial
 30 Milliohms Max. Final
 Durability: 750 Cycles
 Dielectric Withstanding Voltage:
 1000V RMS. At 60Hz, 1 Minute Between
 Adjacent Contacts
 1500V RMS. At 60Hz, 1 Minute Between
 Shield And Contacts
 Housing: PBT+G.F.(UL94V-0), Black
 △ Contact: Phosphor Bronze $\phi 0.45\text{mm}$
 Gold Plated 6u" Over All, Over Nickel
 Cavity Conforms To FCC Rules And Regulations
 Part 68, Subpart F.
 RoHS Compliant

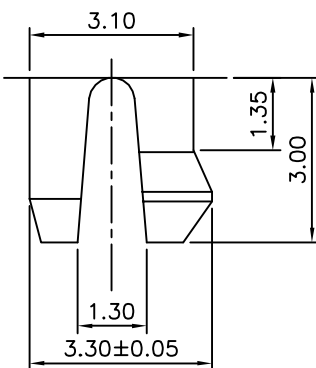

Detail X

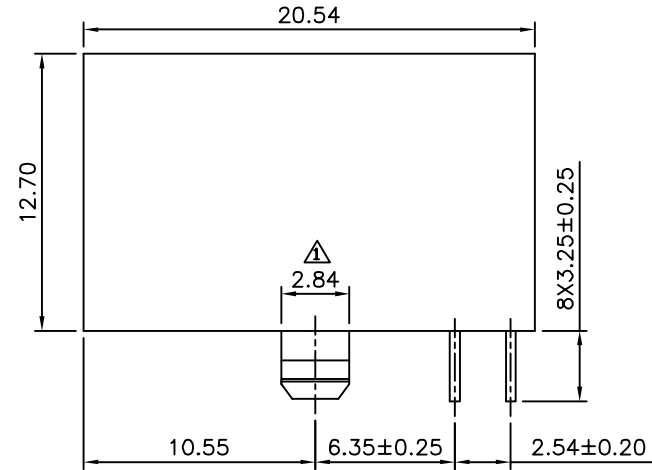
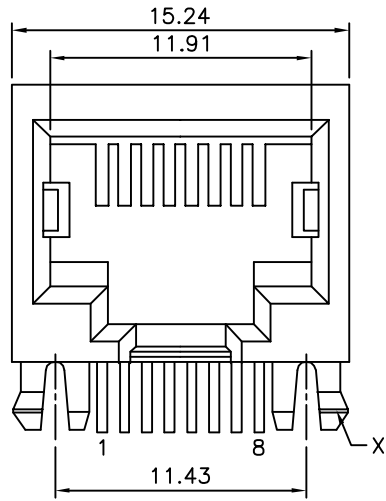
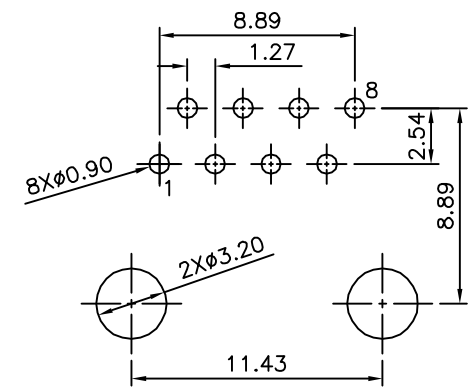
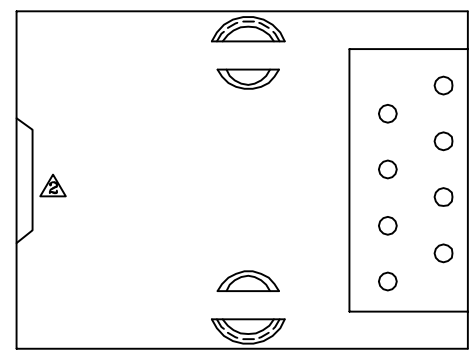

Recommended P.C.B. Layout

4UCON 元化興業股份有限公司
 4UCON TECHNOLOGY INC.

DRAWING No.		APPROVED BY		UNLESS OTHERWISE SPECIFIED TOLERANCES ARE .X ± 0.25 .XX ± 0.13 .XXX ± 0.05 ANG. ± 0.5°
04882		MEI		
		CHECKED BY		
		HZF		
		DRAWING BY		UNIT mm
		CYP		
SCALE	NONE	REV.	A3	NO. REV.

△ A3	Modify Data	HZF	03/31/2017
△ A2	Modify Data	HZF	07/04/2014
△ A1	Modify Data	HZF	11/29/2010
△ A0	NEW RELEASE	HZF	01/18/2008
NO. REV.	REVISIONS	CHK	DATE