

Recommended Mounting Hole  
Max. Panel Thickness: 0.5mm

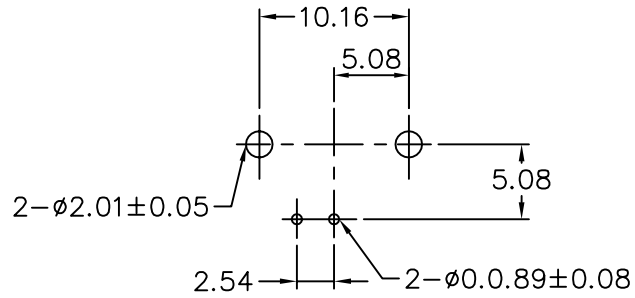

Recommended P.C. Board Layout  
Without Mounting Posts

**SPECIFICATIONS :**

- 75 Ohms BNC R/A PCB Mount Jack
- 1.Center Contact: Bronze,Gold Plated
- 2.Body: Zinc Alloy,Nickel Plated
- 3.Housing :PBT (UL 94V-0)
- 4.Insulator:PE-606
- 5.Mounting Post:Bronze,Tin Plated
- 6.Solder Tail:Coer Wire,Tin Plated
- 7.Washer :Steel,Nickel Plated
- 8.Nut:Brass,Nickel Plated

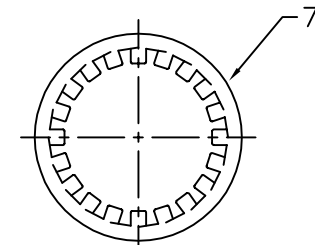
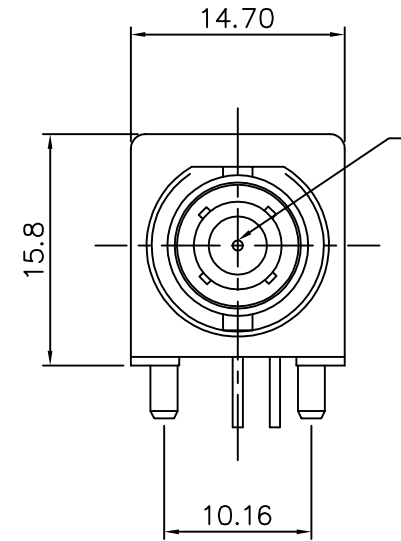
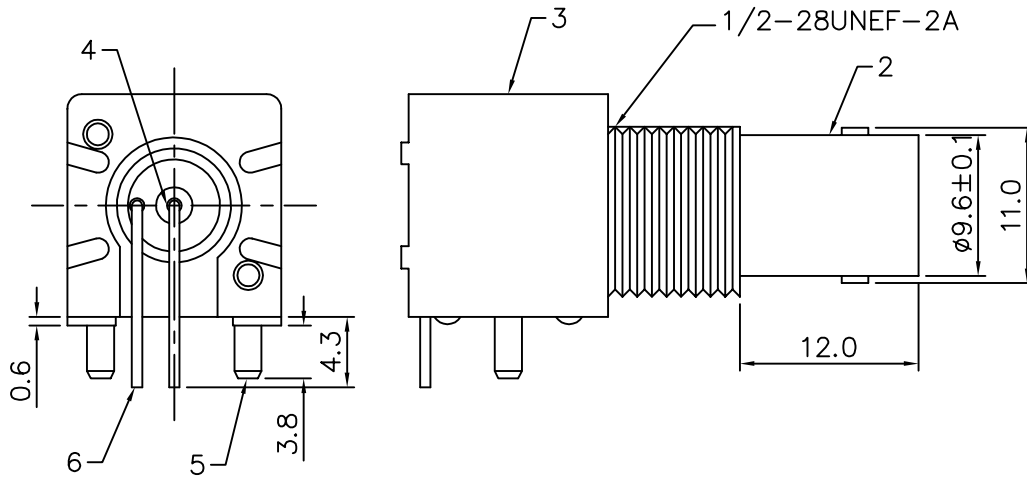

Lock Washer

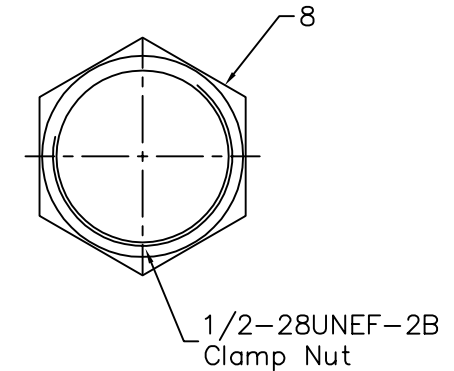

1/2-28UNEF-2B  
Clamp Nut

**4UCON** 元化興業股份有限公司  
4UCON TECHNOLOGY INC.

DRAWING No.

06548

APPROVED BY

MEI

CHECKED BY

RAN

DRAWING BY

HZF

UNLESS OTHERWISE SPECIFIED

TOLERANCES ARE

.X ±0.5

.X ±0.3

.XX ±0.2

SCALE

NONE

REV.

A

UNIT

mm



AREA

REVISIONS

CHK

DATE