

**△ SPECIFICATION**  
 Current:1.0A Max.  
 Voltage:30V Max.  
 Withstanding Voltage:100V AC  
 Insulation Resistance:1000 Megaohms Min.  
 Contact Resistance:30 Milliohms Max.  
 Temperature Range:-55°C~+85°C  
 Mating Force:35N Max.  
 Withdrawal Force:10N Min.  
 Durability:10000 Cycles Min.  
 Insulator:LCP+30%G.F.(UL94V-0),Black  
 Contact:Phosphor Bronze,Gold Flash On Contact Area,Tin Plated On Solder Tails,Over Nickel  
 Shell:Stainless Steel,Nickel Plated Over All  
 RoHS Compliant

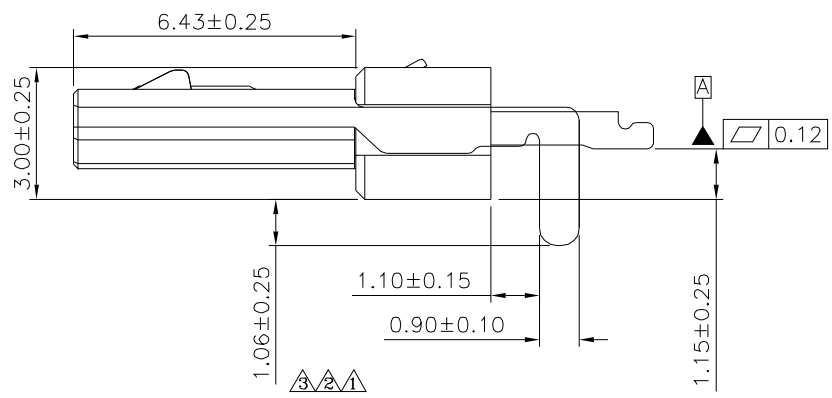
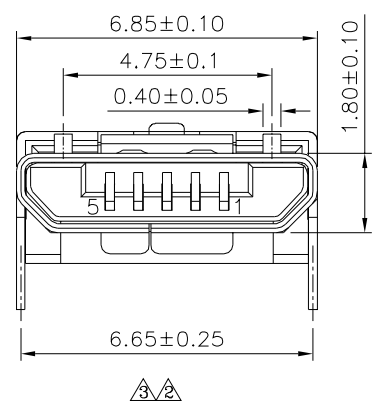

| Pin | Signal Name |
|-----|-------------|
| 1   | VBUS        |
| 2   | D-          |
| 3   | D+          |
| 4   | ID          |
| 5   | GND         |

**4UCON** 元化興業股份有限公司  
 4UCON TECHNOLOGY INC.

|             |      |             |     |  |
|-------------|------|-------------|-----|--|
| DRAWING No. |      | APPROVED BY |     | UNLESS OTHERWISE SPECIFIED TOLERANCES ARE<br>△.X ±0.38 .X* ±2*<br>.XX ±0.25 .XX* ±1*<br>.XXX ±0.13 .XXX* ±0.5* |
| 18499       |      | MEI         |     |  |
|             |      | CHECKED BY  | HZF |  |
|             |      | DRAWING BY  | CYP |  |
| SCALE       | NONE | REV.        | A3  | UNIT<br>mm   |

| NO. | REV. | REVISIONS   | CHK | DATE       |
|-----|------|-------------|-----|------------|
| △3  | A3   | Modify Data | HZF | 02/16/2023 |
| △2  | A2   | Modify Data | HZF | 06/08/2016 |
| △1  | A1   | Modify Data | HZF | 08/07/2014 |
| △0  | A0   | NEW RELEASE | HZF | 07/31/2012 |