

SPECIFICATIONS
SMA PANEL CRIMP JACK FOR RG 316/U
 1.Crimped Ferrule
 Hex Crimp Size .128"(3.25mm)
 2.Contact Pin To Solder

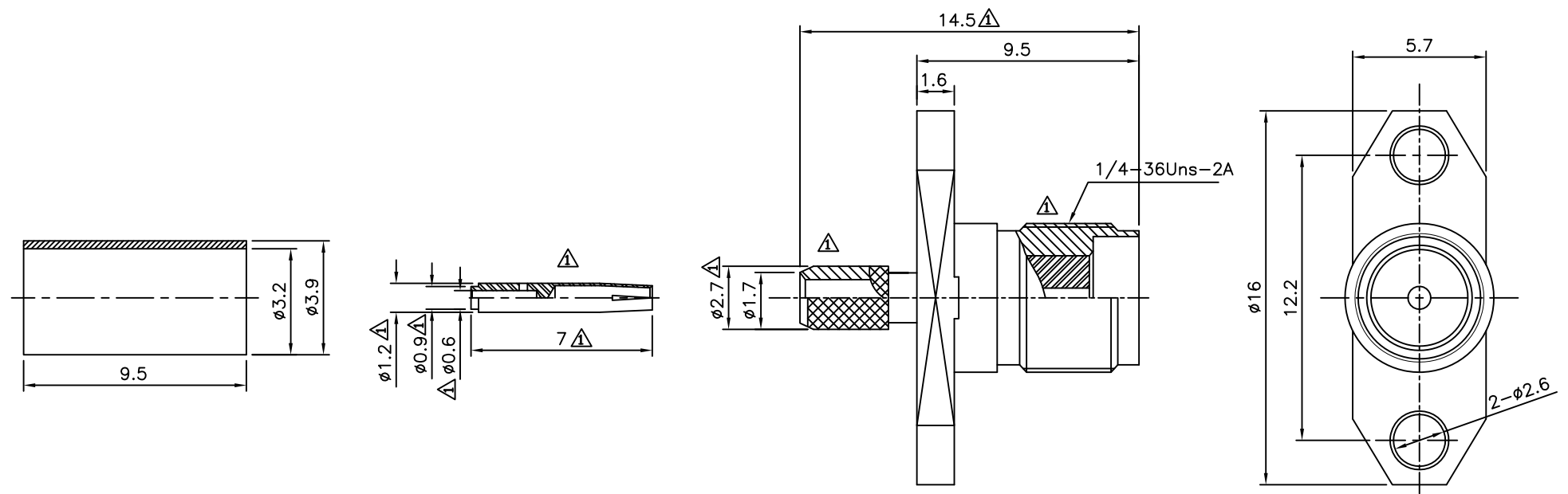

Recommended Cable Stripping Dim's

- NOTES:**
 Finish (Plating Thickness In Micro-Inches)
 1.Brass PER QQ-B-626
 2.Gold PL 3 Min Over Nickel PL 70 Min Thick Over Copper Stricke
 3.Gold PL 30 Min Over Nickel PL 70 Min Thick Over Copper Stricke
 4.Teflon MIL-P-19468
 5.Beryllium Copper PER QQ-B-530
 6.Brass JIS H 3250 C 2700

Ferrule	Note 6	Note 2
Contact Pin	Note 5	Note 3
Insulator	Note 4	White
Body	Note 1	Note 2
Desctiption	Material	Finish

4UCON 元化興業股份有限公司
 4UCON TECHNOLOGY INC.

DRAWING No.		APPROVED BY		UNLESS OTHERWISE SPECIFIED TOLERANCES ARE 0.5~6 ±0.2 >6~30 ±0.4 >30~120 ±0.6 ANG ±5°
18696		MEI		
		CHECKED BY HZF		
		DRAWING BY PEGA		
SCALE	NONE	REV.	A1	UNIT mm

NO.	REV.	REVISIONS	CHK	DATE
△	A1	UPDATE DRAWING	HZF	09/27/2007
△	A0	NEW RELEASE	HZF	02/20/2004