

SPECIFICATION

Rating:DC 20V 3A
 Withstanding Voltage:500V AC
 Contact Resistance:50 Milliohms Max.
 After Test:100 Milliohms Max.
 Insulation Resistance:100 Megaohms Min. (500V DC)
 After Test:50 Megaohms Min.
 Insertion And Extraction Force:3~30N
 Life Test:5000 Cycles Min.
 Operation Temperature Range:-20°C~+70°C
 Preservative Temperature Range:-40°C~+85°C
 RoHS Compliant

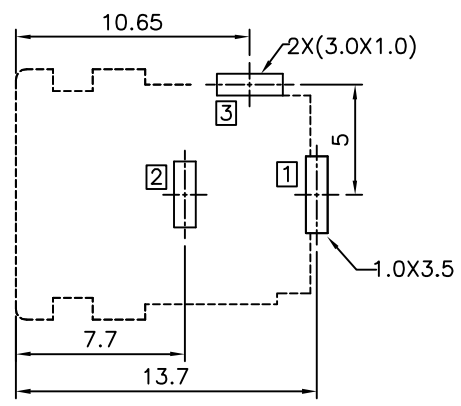

Recommended P.C.B. Layout(Bottom View)
 (PCB Board Tolerance±0.05)

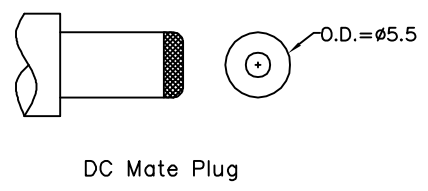
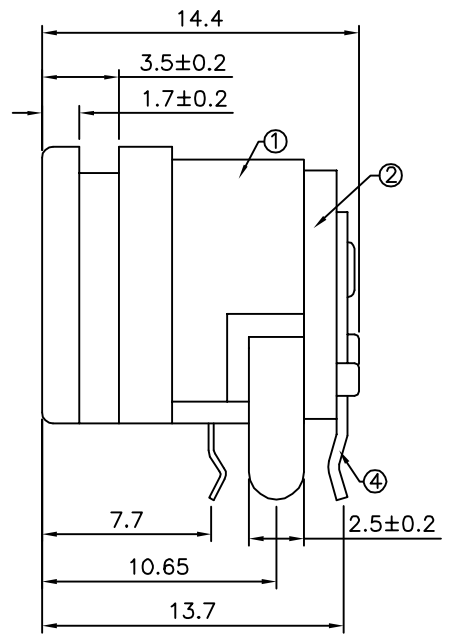
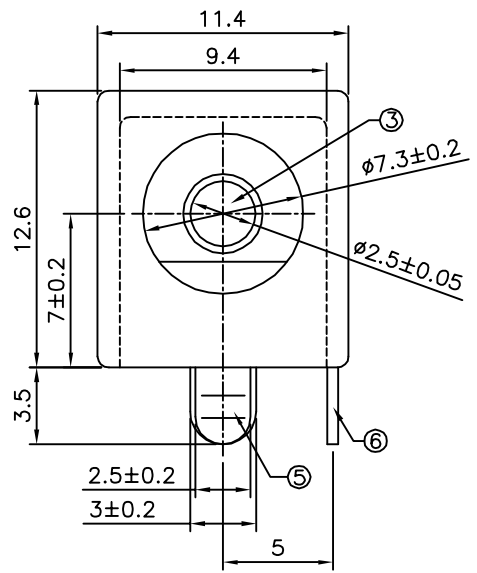
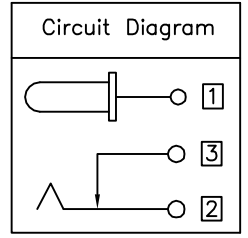

No.	Description	Q'ty	Material	Remark
⑥	Shunt Terminal	1	Brass	Tin Plated
⑤	Tip Spring	1	Stainless Steel	Tin Plated
④	Center Pin Terminal	1	Brass	Tin Plated
③	Center Pin	1	Brass	Nickel Plated
②	Cover	1	PBT	Black
①	Housing	1	PBT	Black

4UCON 元化興業股份有限公司
 4UCON TECHNOLOGY INC.

DRAWING No.		APPROVED BY		UNLESS OTHERWISE SPECIFIED TOLERANCES ARE X. ±0.3 .X ±0.3 .XX ±0.3 ANG. ±2°
20861		MEI		
		CHECKED BY		
		HZF		
		DRAWING BY		
		CYP		
SCALE	NONE	REV.	A0	UNIT mm

NO.	REV.	REVISIONS	CHK	DATE
△ A0		NEW RELEASE	HZF	11/26/2015