

△△ SPECIFICATION

- 1. Material & Finish**
 Contact: Phosphor Bronze, Gold Flash Over Nickel
 Insulator: LCP (UL94V-0)
 Shell: Stainless Steel, Nickel Plated Over All
- 2. Electrical Characteristics**
 Current Rating: 1A
 Voltage Rating: 30V
 Withstand Voltage: 500V AC/Mimute
 Contact Resistance: 30 Milliohms Max.
 Insulation Resistance:
 Unmated: 1000 Megaohms Min.
 Mated: 100 Megaohms Min.
- 3. Mechanical Characteristics**
 Mating Cycle: 3000 Cycles
 Contact Retention: 50gf/Pin Min.
- 4. Environmental Characteristics**
 Operation Temperature: -25°C ~ +70°C
 Storage Temperature: -10°C ~ +40°C
- 5. RoHS Compliant**

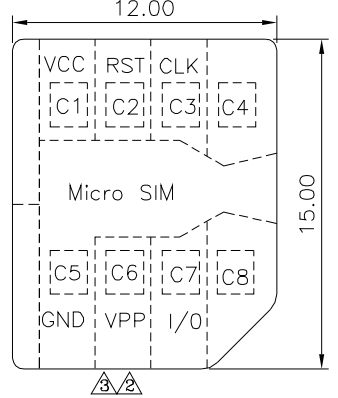

Pin No.	Name
C1	VCC
C2	RST
C3	CLK
C4	Reserved
C5	GND
C6	VPP
C7	I/O
C8	Reserved

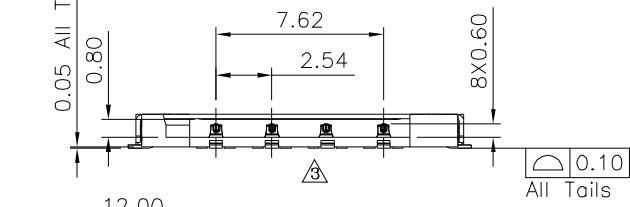
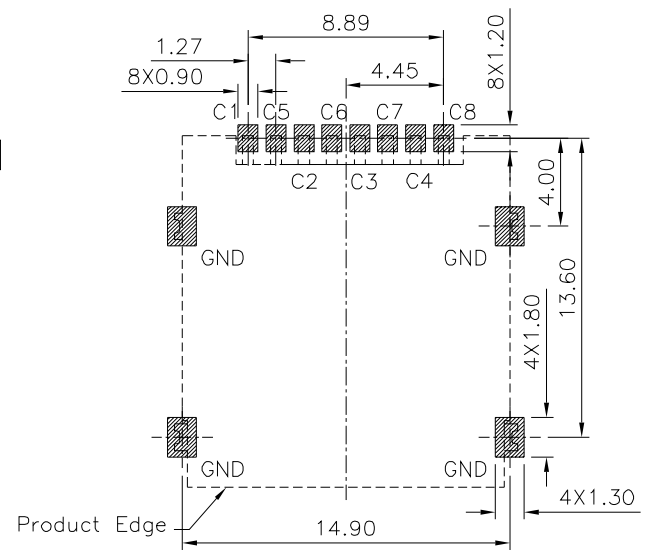

△△ Recommended P.C.B. Layout (Top View)
 (PCB Board Tolerance ±0.05)

4U CON 元化興業股份有限公司
 4U CON TECHNOLOGY INC.

DRAWING No. △		APPROVED BY		UNLESS OTHERWISE SPECIFIED TOLERANCES ARE X. ±0.45 X.* ±5° .X ±0.35 △ .X* ±2° .XX ±0.25 .XX* ±1° .XXX ±0.15 .XXX* ±0.5°
21136		MEI		
SCALE	NONE	CHECKED BY	HZF	
		DRAWING BY	CYP	
		REV.	A3	UNIT mm

△ A3	Modify Data	HZF	05/20/2020
△ A2	Modify Data	HZF	10/31/2017
△ A1	Modify Data	HZF	09/14/2016
△ A0	NEW RELEASE	HZF	02/03/2016
NO. REV.	REVISIONS	CHK	DATE