

Detail D

SPECIFICATION

Withstanding Voltage: 300V AC/Max.
 Insulation Resistance: 1000 Megaohms Min.
 Voltage Rating: 30V DC/AC (RMS) Max.
 Current Rating: 0.5A Max.
 Operation Temperature: -40°C~+85°C
 Storage Temperature: -55°C~+105°C
 Durability: 100 Cycles Min.
 Insertion And Fxtraction Force: 40N Max. & 12.5N Max.
 Low Level Contact Resistance(LLCR): ΔR 10 Milliohms Max.
 For Shield And Signal Contacts
 Contact: Phosphor Bronze
 Gold Plated 30u" On Contact Area, Tin
 Plated On Solder Tails, Over Nickel
 Connector Housing: LCP(UL94V-0), Black
 Moulded Insert: LCP(UL94V-0), Black
 Light Pipes: PC(UL94V-0), Clear
 Light Pipe Housing: PBT(UL94V-0), Black
 Cage: Copper Alloy
 EMI Clip: Copper Alloy
 RoHS Compliant

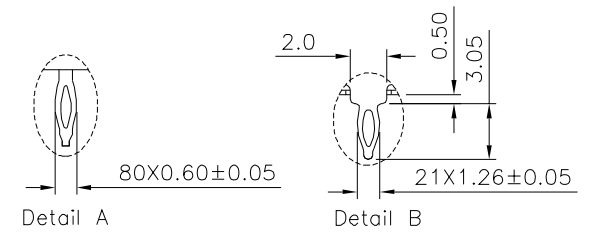
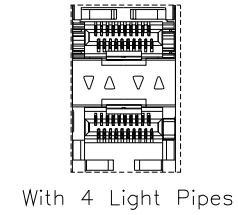
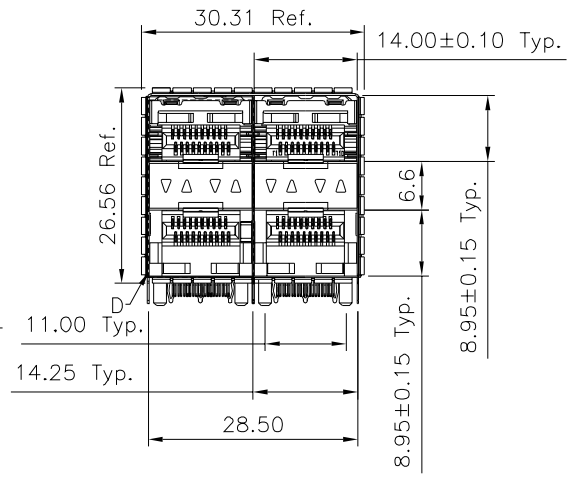
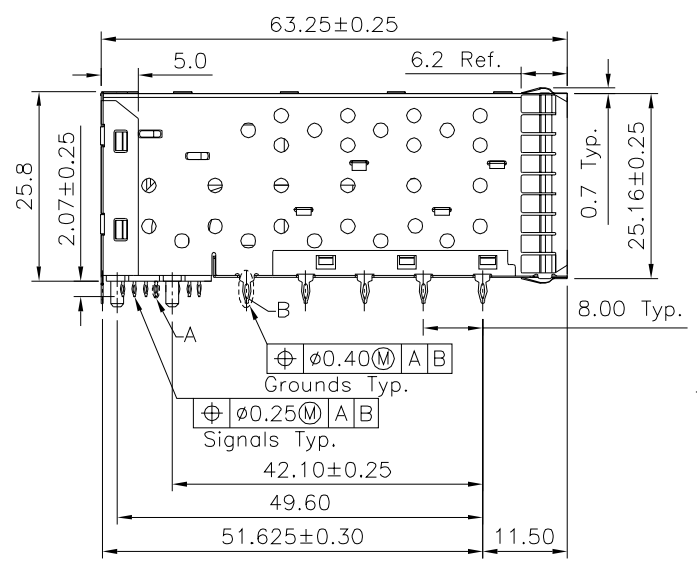

4UCON 元化興業股份有限公司
 4UCON TECHNOLOGY INC.

DRAWING No.		APPROVED BY		UNLESS OTHERWISE SPECIFIED TOLERANCES ARE .X ±0.25 .XX ±0.13 .XXX ±0.10 ANG. ±2°
21932		MEI		
		HZF		
		DRAWING BY		UNIT mm
		CYP		
SCALE	NONE	REV.	A0	UNIT mm

△ A0	NEW RELEASE	HZF	10/11/2019
NO. REV.	REVISIONS	CHK	DATE

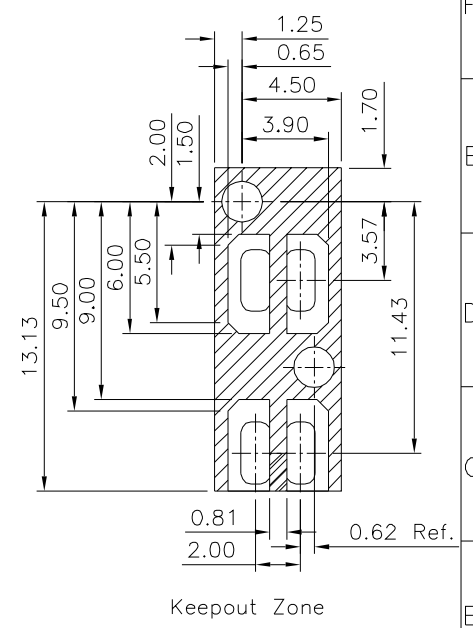
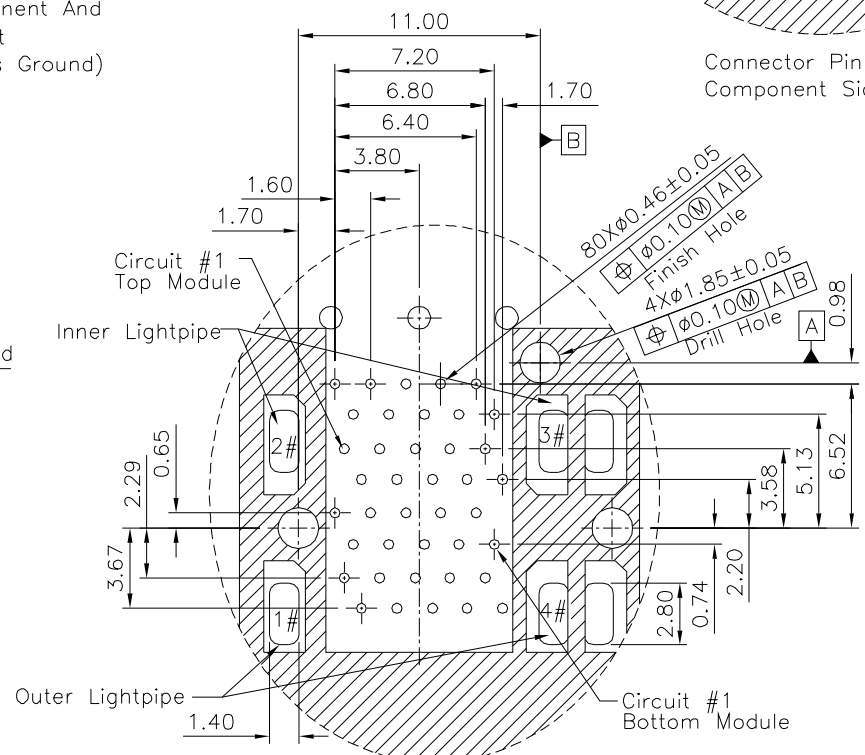
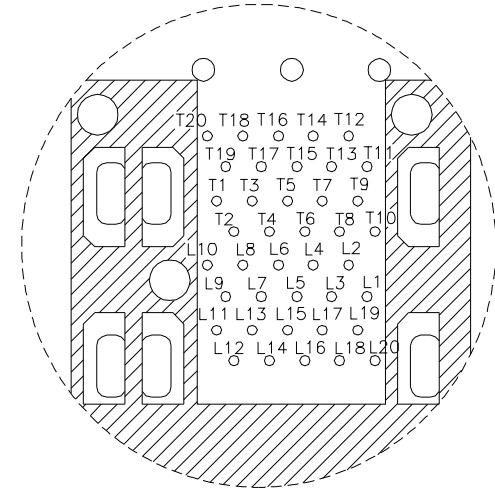
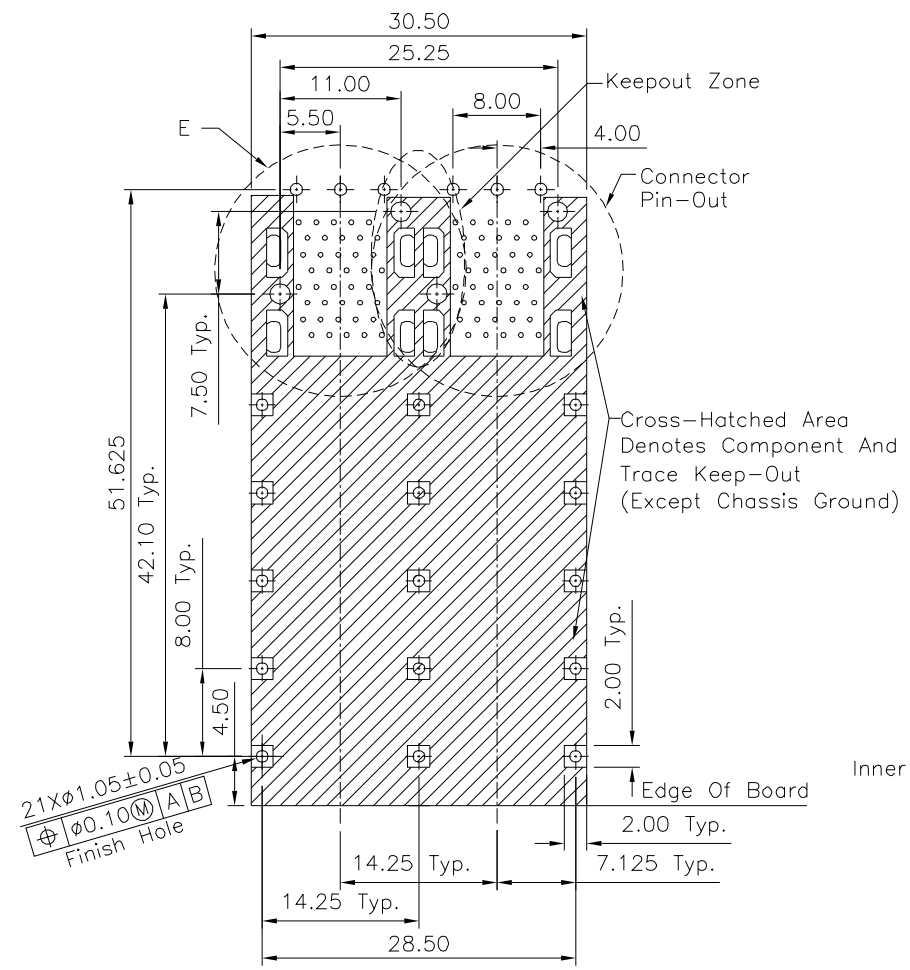

4UCON 元化興業股份有限公司
4UCON TECHNOLOGY INC.

DRAWING No.		APPROVED BY		UNLESS OTHERWISE SPECIFIED TOLERANCES ARE .X ±0.25 .XX ±0.13 .XXX ±0.10 ANG. ±2°				
21932		MEI						
		HZF						
		DRAWING BY		UNIT mm	A0 NEW RELEASE	HZF	10/11/2019	
SCALE	NONE	REV.	A0					NO. REV.