

SPECIFICATION

- 1. Material & Finish**
 Housing: LCP(UL94V-0), Nature
 Actuator: LCP(UL94V-0), Black
 Contact: Phosphor Bronze, Gold Flash Over All, Over Nickel
 Peg: Phosphor Bronze, Tin Plated Over Nickel
- 2. Electrical Characteristics**
 Operating Voltage: 50V RMS AC
 Current Rating: 0.5A
- 3. Environmental Characteristics**
 Temperature Range: -55°C ~ +85°C
- 4. RoHS Compliant**

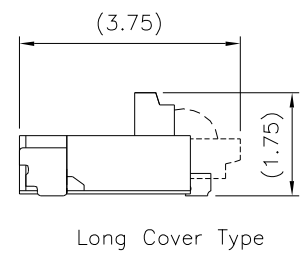
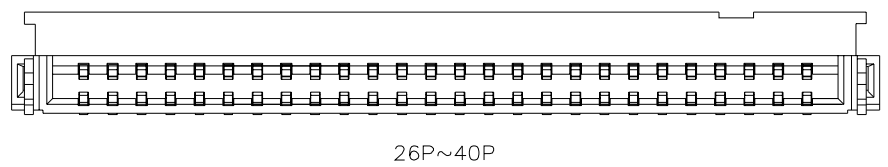
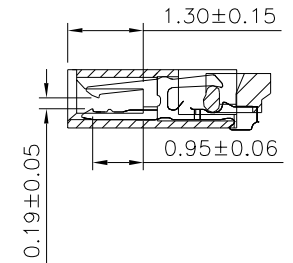
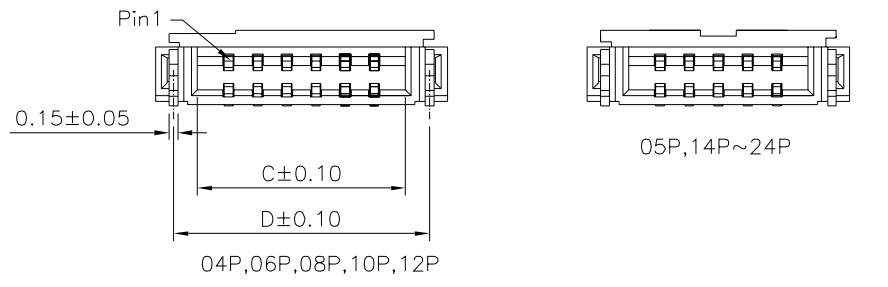
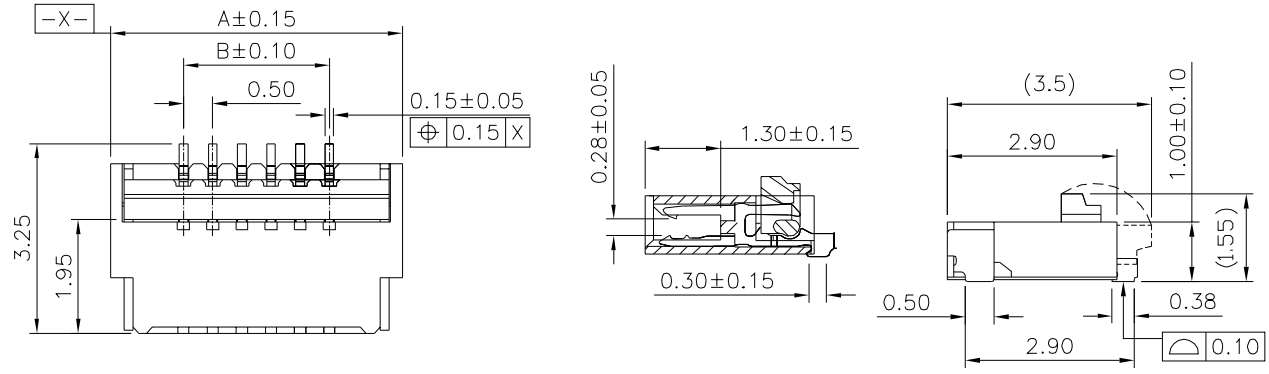

Pin	A	B	C	D	E	F	G	
*4	4.00	1.50	2.57	3.39	3.10	3.90	2.50	—
*5	4.50	2.00	3.07	3.89	3.60	4.50	3.00	
*6	5.00	2.50	3.57	4.39	4.10	4.90	3.50	
*8	6.00	3.50	4.57	5.39	5.10	5.90	4.50	
*10	7.00	4.50	5.57	6.39	6.10	6.90	5.50	
*12	8.00	5.50	6.57	7.39	7.10	7.90	6.50	
*14	9.00	6.50	7.57	8.39	8.10	8.90	7.50	
*16	10.00	7.50	8.57	9.39	9.10	9.90	8.50	
*18	11.00	8.50	9.57	10.39	10.10	10.90	9.50	
*20	12.00	9.50	10.57	11.39	11.10	11.90	10.50	
*22	13.00	10.50	11.57	12.39	12.10	12.90	11.50	
*24	14.00	11.50	12.57	13.39	13.10	13.90	12.50	
*26	15.00	12.50	13.57	14.39	14.10	14.90	13.50	
*28	16.00	13.50	14.57	15.39	15.10	15.90	14.50	
*30	17.00	14.50	15.57	16.39	16.10	16.90	15.50	
*32	18.00	15.50	16.57	17.39	17.10	17.90	16.50	
*34	19.00	16.50	17.57	18.39	18.10	18.90	17.50	
*40	22.00	19.50	20.57	21.39	21.10	21.90	20.50	

The Mark Of "*" Are Tooled

4UCON 元化興業股份有限公司
 4UCON TECHNOLOGY INC.

DRAWING No.		APPROVED BY		UNLESS OTHERWISE SPECIFIED TOLERANCES ARE	
22767		MEI		.X ±0.30 .X* ±5*	
		HZF		.XX ±0.20 .XX* ±2*	
		CYP			
SCALE	NONE	REV.	B1	UNIT	mm

NO.	REV.	REVISIONS	CHK	DATE
△	B1	Modify Data	HZF	01/12/2024
△	B0	NEW RELEASE	HZF	10/11/2023

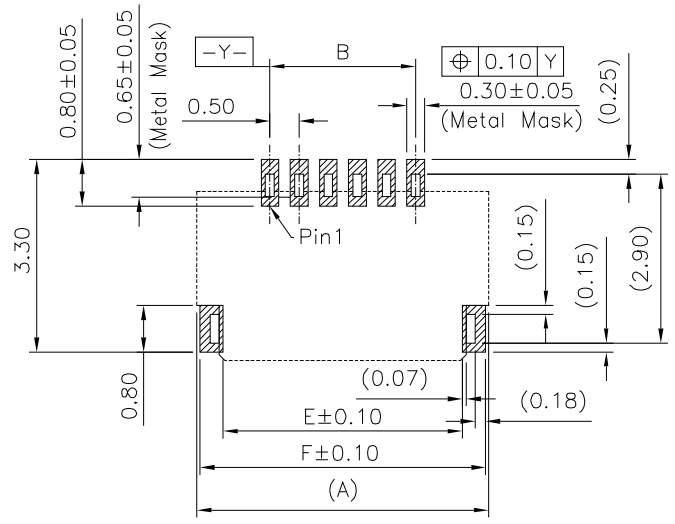

△ Recommended PCB Layout

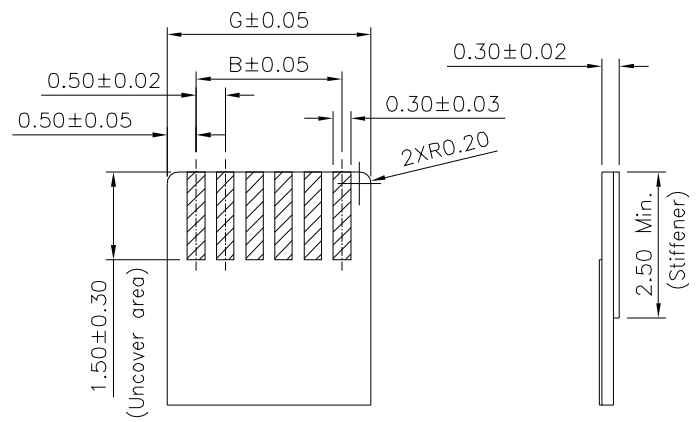

Recommended FPC/FFC Dimensions

4UCON 元化興業股份有限公司
4UCON TECHNOLOGY INC.

DRAWING No.
22767

APPROVED BY
MEI
CHECKED BY
HZF
DRAWING BY
CYP

UNLESS OTHERWISE SPECIFIED TOLERANCES ARE
.X ±0.30 .X* ±5°
.XX ±0.20 .XX* ±2°
UNIT mm

NO.	REV.	REVISIONS	CHK	DATE
△ B1		Modify Data	HZF	01/12/2024
△ B0		NEW RELEASE	HZF	10/11/2023

SCALE NONE REV. B1

