

**SPECIFICATIONS**

**ELECTRICAL CHARACTERISTICS:**

Contact Current Rating:3 Amperes.  
 Dielectric Withstanding Voltage: AC 1000/60sec.r.m.s.  
 Insulation Resistance:5000 Medohms Minimum.at DC 500V.  
 Contact Resistance:25 Milliohms Maximum.  
 Operating Temperature:-55°C to+105°C.

**MECHANICAL CHARACTERISTICS:**

Contact Insertion Force:341 g.Maximum.  
 Contact Separation Force:21 g.Minimum.

**MATERIALS:**

Contacts:Brass.  
 Insulator: PBT UL 94V-0 Rated.  
 Shell: Cold Roller Steel.

**FINISHES:**

Contact:Gold Flash.  
 Shell:Nickel Plated.

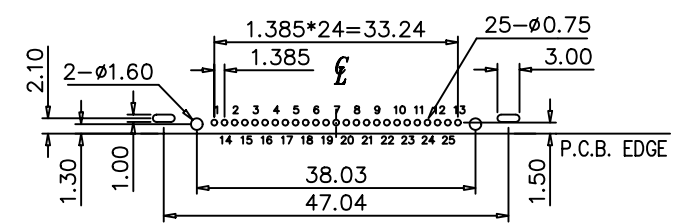
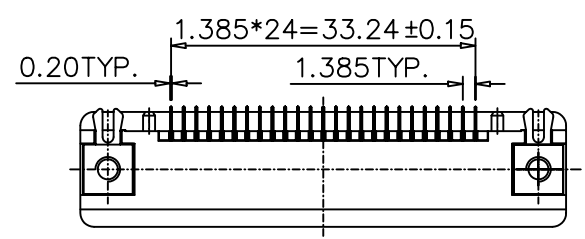
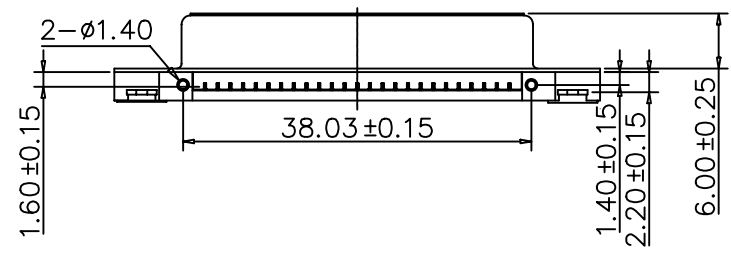
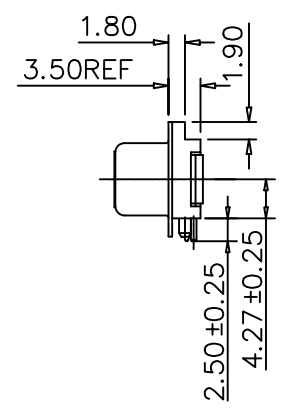
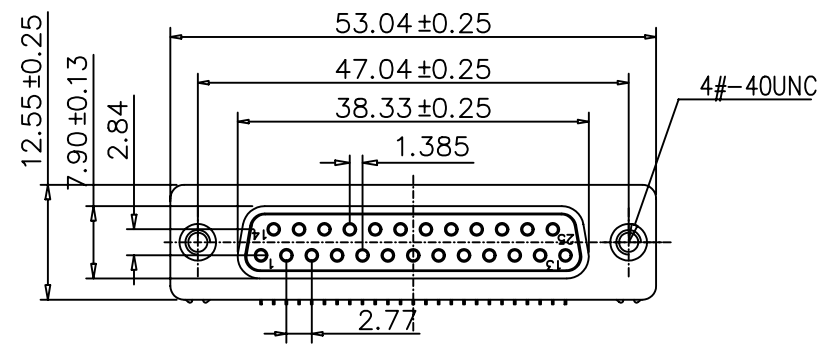

Recommend PCB Layout

**4UCON** 元化興業股份有限公司  
 4UCON TECHNOLOGY INC.

DRAWING No.  
 09781

APPROVED BY MEI  
 CHECKED BY RAN  
 DRAWING BY HZF

UNLESS OTHERWISE SPECIFIED  
 TOLERANCES ARE  
 .X ±0.25  
 .XX ±0.13  
 ANG. ±2°

SCALE NONE

REV. A0

UNIT mm

AREA REVISIONS CHK DATE