

Recommended P.C.B. Layout

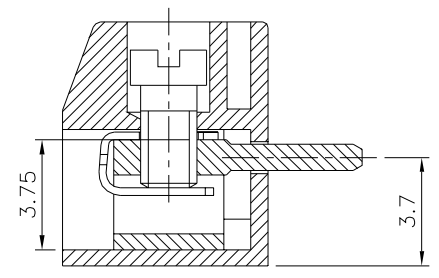
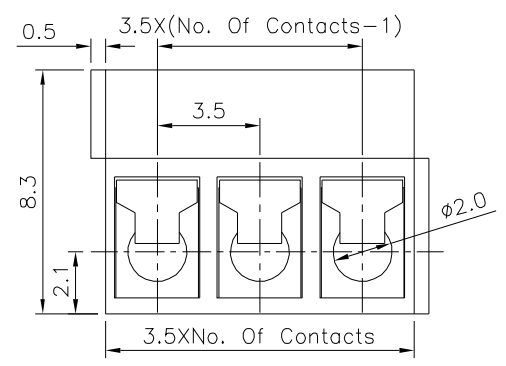
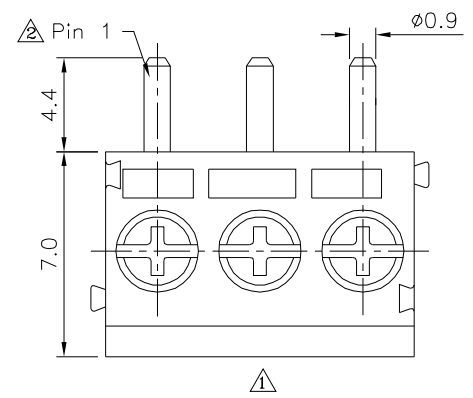

△ SPECIFICATION

- Voltage Rating:150V AC
- Current Rating:10 Amps/Way Max.
- Contact Resistance:20 Milliohms Max.
- Withstanding Voltage:2000V AC(1 Minute)
- Test Time=60 Sec/1 PCS
- Wire Range:16~30 AWG
- Torque:2.0 Kgf.cm/M2
- Operation Temperature:-40°C~+105°C
- Soldering Reliability:
- Test Temperature=250°C±10°C/5Seconds Max.
- Terminal:Copper Alloy,Tin Plated
- Screw:Steel,Galvanized With Cr3+ Plated
- Wire Guard:Stainless Steel
- △ Insulator Body(Housing):Polyamide.(UL94V-0),Blue
- RoHS Compliant

4UCON 元化興業股份有限公司
4UCON TECHNOLOGY INC.

DRAWING No. △
10696

APPROVED BY MEI
CHECKED BY HZF
DRAWING BY CYP

UNLESS OTHERWISE SPECIFIED TOLERANCES ARE
X. ±0.50
.X ±0.30
.XX ±0.20
X° ±1°

SCALE NONE

REV. A2

UNIT mm

NO.	REV.	REVISIONS	CHK	DATE
△2	A2	Modify Data	HZF	12/10/2019
△1	A1	Modify Data	HZF	12/16/2014
△0	A0	NEW RELEASE	HZF	06/05/2011