

SPECIFICATION

Current Rating: 1 Amps
 Withstanding Voltage: 500V(One Minute)
 Contact Resistance: 30 Milliohms Max.
 Insulation Resistance: 1000 Megaohms Min.
 At 500V DC
 Operating Temperature: -40°C~+85°C
 Shell: SPCC,Nickel Plated
 Insulator: PBT+30%G.F.(UL94V-0)
 Contact: C2680,Gold Flash On Contact Area,
 Tin Plated On Solder Tails,Over Nickel
 Boardlock: SPCC,Tin Plated
 Rivet: C3604,Nickel Plated
 Screw: 12L14,Nickel Plated
 RoHS Compliant

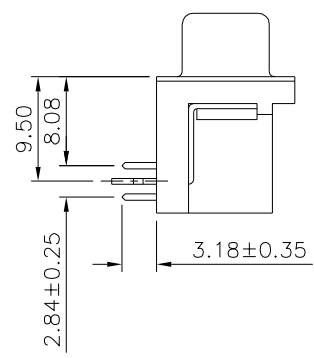
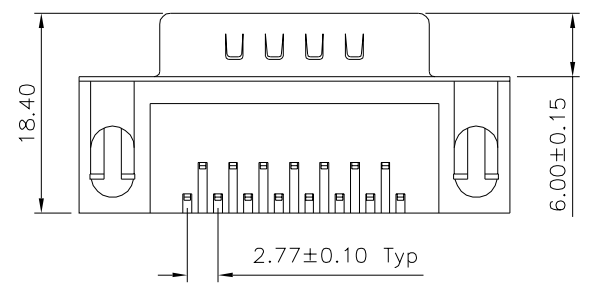
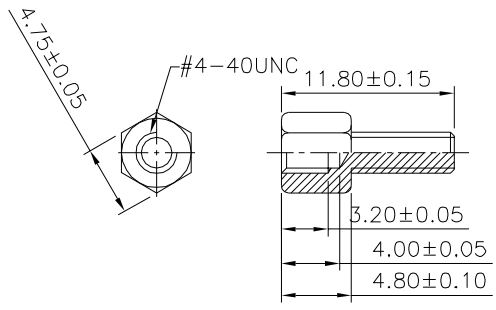
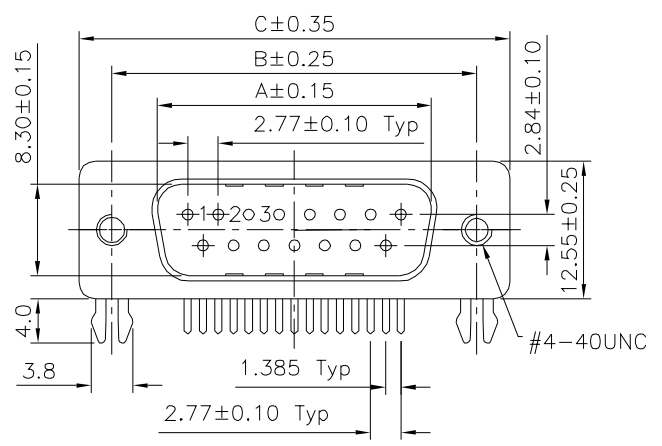
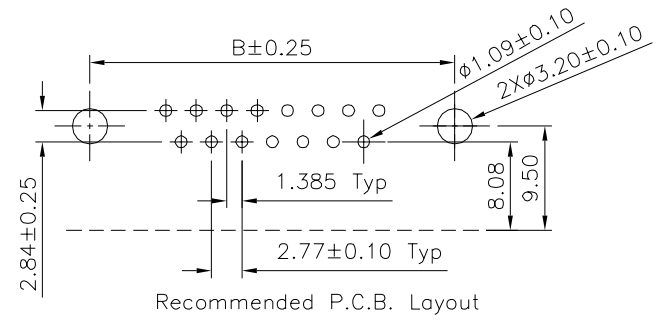

Pin	A	B	C
09	16.92	24.99	30.81
15	25.25	33.32	39.20
25	38.96	47.04	53.04
37	55.42	63.50	69.40

4UCON 元化興業股份有限公司
 4UCON TECHNOLOGY INC.

DRAWING No.		APPROVED BY		UNLESS OTHERWISE SPECIFIED TOLERANCES ARE .X ±0.38 .X* ±3* .XX ±0.25 .XX* ±1* .XXX ±0.05 .XXX* ±0.5*
18603		MEI		
		HZF		
		DRAWING BY		
		CYP		
SCALE	NONE	REV.	BO	UNIT mm

NO.	REV.	REVISIONS	CHK	DATE
△	B0	NEW RELEASE	HZF	08/06/2019