

SPECIFICATION
 Rating:DC 30V 0.5A
 Withstand Voltage:500V AC
 Contact Resistance:30 Milliohms Max.
 Insulation Resistance:100 Megaohms Min. (500V DC)
 Operation Temperature Range:-20°C~+70°C
 Preservative Temperature Range:-40°C~+85°C
 Insertion And Extraction Force:3~30N
 Life Test:5000 Cycles
 RoHS Compliant

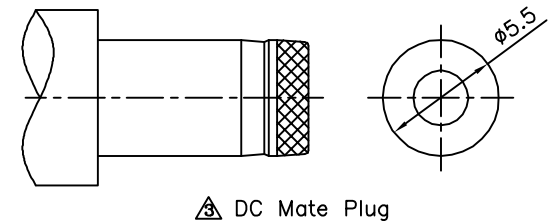
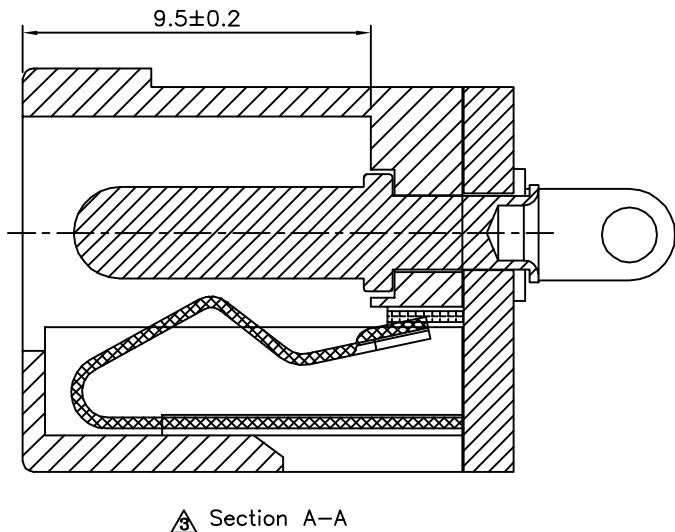
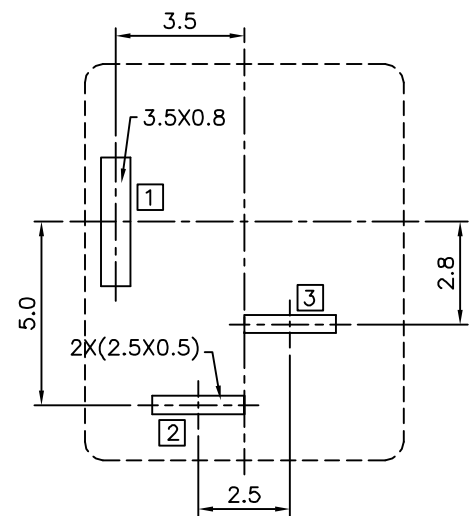
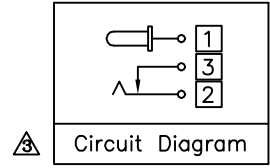

⑥	Shunt Terminal	3	1	Brass	Silver Plated
⑤	Tip Spring	2	1	Phosphor Bronze	Silver Plated
④	Center Pin Terminal	1	1	Brass	Silver Plated
③	Center Pin	1	1	Brass	Nickel Plated
②	Cover		1	PBT	Black
①	Housing		1	PBT	Black
No.	Description	Q'ty		Material	Remark

Recommended P.C.B. Layout(Copper-Sided View)

○ :Item No. □ :Terminal No.

4UCON 元化興業股份有限公司
 4UCON TECHNOLOGY INC.

DRAWING No.		APPROVED BY		UNLESS OTHERWISE SPECIFIED TOLERANCES ARE .X ±0.3 .XX ±0.3 ANG. ±2°
18918		EMILY		
		HZF		
		DRAWING BY		UNIT mm
		SONG		
SCALE	NONE	REV.	A3	

NO.	REV.	REVISIONS	CHK	DATE
A3		Modify Data	HZF	03/22/2013
A2		Modify 5.00 → 4.40	HZF	09/16/2008
A1		ADD DIM	HZF	08/21/2008
A0		NEW RELEASE	INGRID	08/16/2007