

Recommended P.C.B. Layout

△△ SPECIFICATION
 Current Rating: 10 Amp/Way Max.
 Voltage Rating: 150V AC
 Withstanding Voltage: 2000V AC/Minute
 Test Time=60 Seconds/Pcs
 Contact Resistance: 20 Milliohms Max.
 Wire Range: 16~30AWG
 Torque: 2.0 Kgf.cm/M2
 Operation Temperature: -40°C~+105°C
 Soldering Reliability: Test Temperature=250°C±10°C
 5 Seconds Max.
 Terminal: Copper Alloy, Tin Plated
 Screw: Steel, Galvanized And With Cr3+ Plated
 Wire Guard: Stainless Steel
 Insulator: Polyamide(UL94V-0), Black
 RoHS Compliant

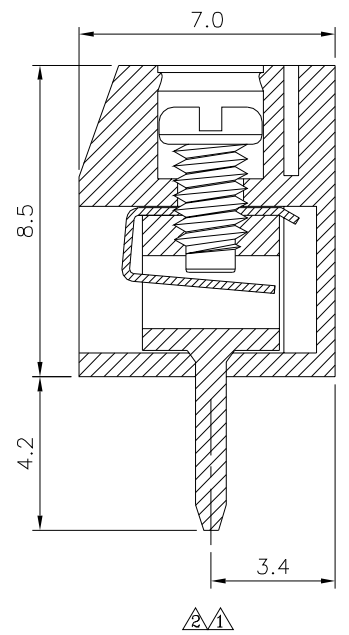
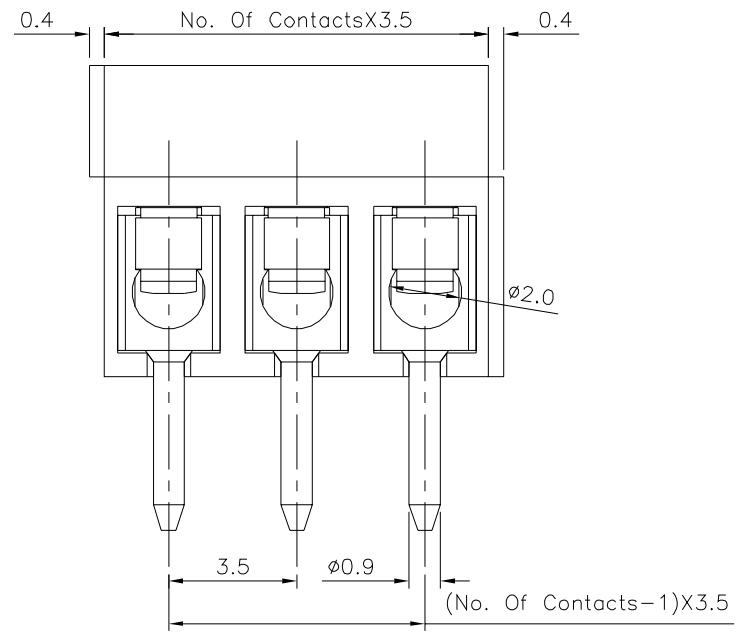

4UCON 元化興業股份有限公司
 4UCON TECHNOLOGY INC.

| | | | | |
|-------------|------|-------------|-----|--|
| DRAWING No. | | APPROVED BY | | UNLESS OTHERWISE SPECIFIED TOLERANCES ARE X. ±0.50 .X ±0.30 .XX ±0.20 ANG. ±1° |
| 21007 | | MEI | | |
| | | CHECKED BY | HZF | |
| | | DRAWING BY | CYP | |
| SCALE | NONE | REV. | A3 | UNIT mm |

| | | | | |
|-----|------|-------------|-----|------------|
| NO. | REV. | REVISIONS | CHK | DATE |
| △3 | A3 | Modify Data | HZF | 04/05/2017 |
| △2 | A2 | Modify Data | HZF | 09/15/2014 |
| △1 | A1 | Modify Data | HZF | 05/19/2011 |
| △0 | A0 | NEW RELEASE | HZF | 03/08/2010 |