

SPECIFICATION
 Rating:DC 30V,0.5A
 Withstand Voltage:500V AC
 Contact Resistance:30 Milliohms Max.
 After Test:50 Milliohms Max.
 Insulation Resistance:100 Megaohms Min. (500V DC)
 After Test:50 Megaohms Min.
 Insertion And Extraction Force:3N~30N
 Life Test:5000 Cycles Min.
 Operation Temperature Range:-20°C~+70°C
 Presservation Temperature Range:-40°C~+85°C
 RoHS Compliant

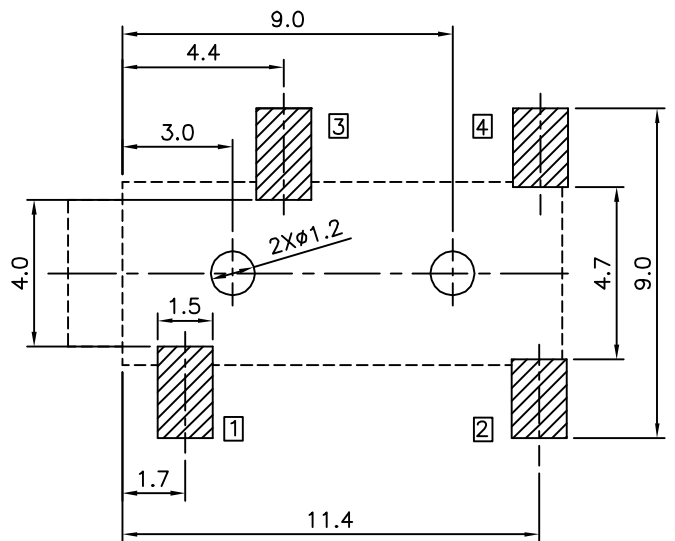

Recommended P.C.B. Layout(Top Side)
 (PCB Board Tolerance±0.05)

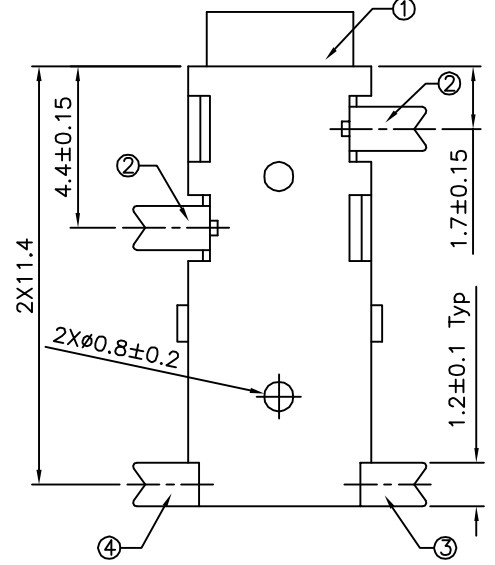
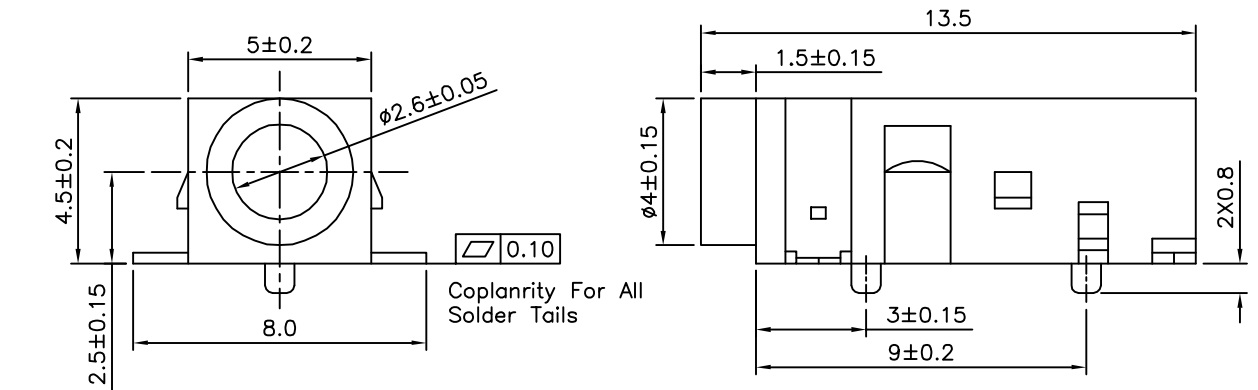
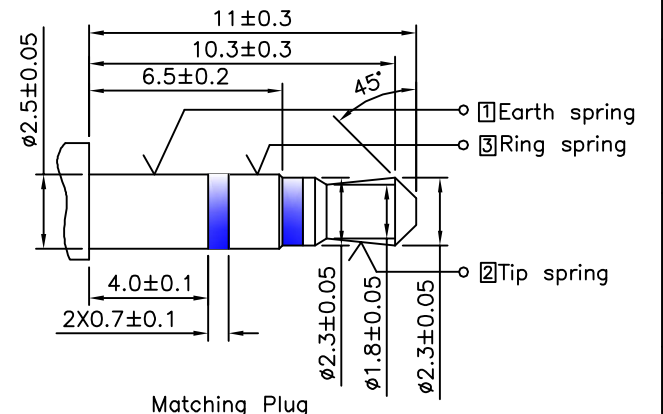

④ Shunt Terminal	4	1	Brass	Silver Plated
③ Tip Spring	2	1	Phosphor Bronze	Silver Plated
② Ring Spring	1	3	Phosphor Bronze	Silver Plated
① Housing		1	PA9T	Black
NO. Description	Q'ty	Material	Remark	

Item No.	18901	18900
Schematic		

4UCON 元化興業股份有限公司
 4UCON TECHNOLOGY INC.

DRAWING No.		APPROVED BY		UNLESS OTHERWISE SPECIFIED TOLERANCES ARE .X ±0.3 X. ±0.3 ANG. ±2°
18901		EMILY		
		CHECKED BY HZF		
		DRAWING BY GAO		
SCALE	NONE	REV.	BO	UNIT mm

△ BO	NEW RELEASE	HZF	01/15/2013
NO. REV.	REVISIONS	CHK	DATE

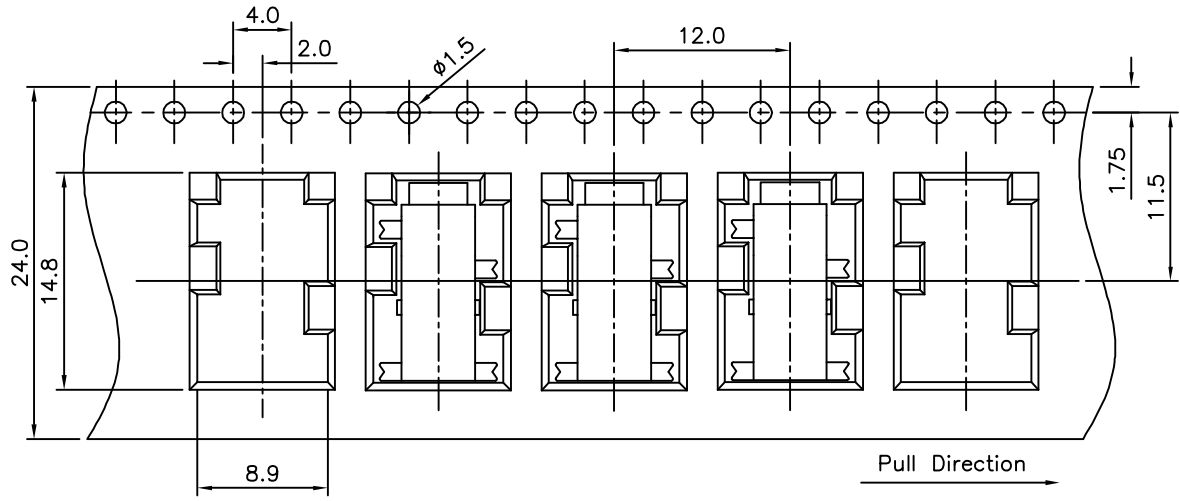

SPECIFICATION

Before Packing, Keep 160mm Empty In The Front Carriers Don't Need To Pack. After Packed, Keep 400mm Empty In The Back Carriers, But Cover Tapes Are Longer 130mm Than The Carriers.
 Q'ty: 1000 PCS/Reel
 RoHS Compliant

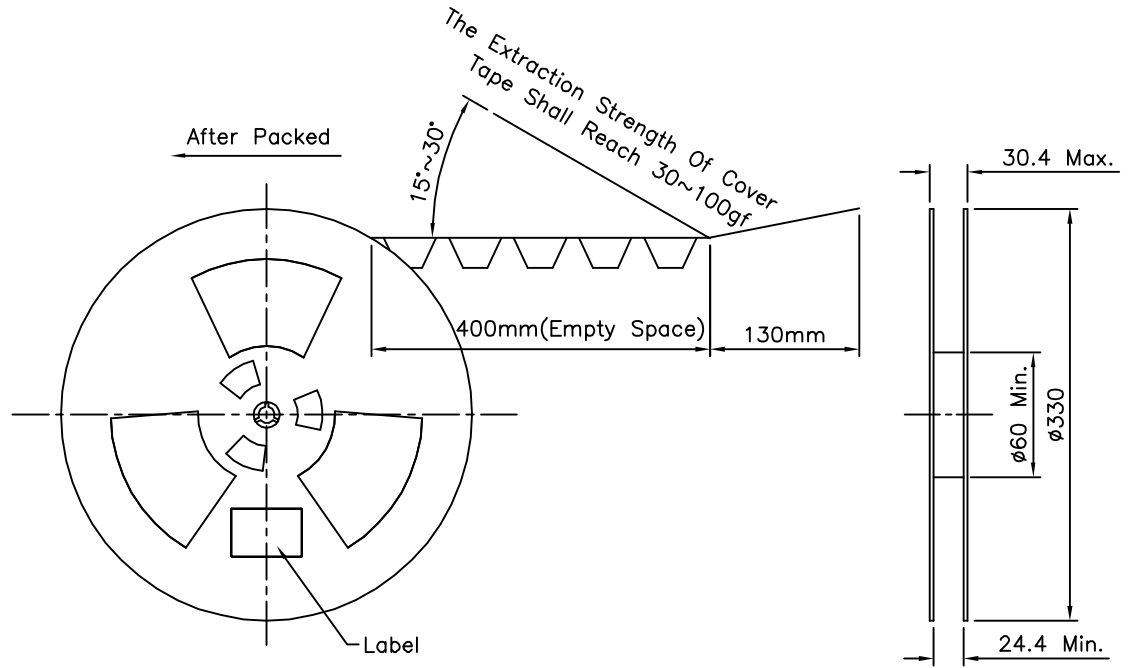
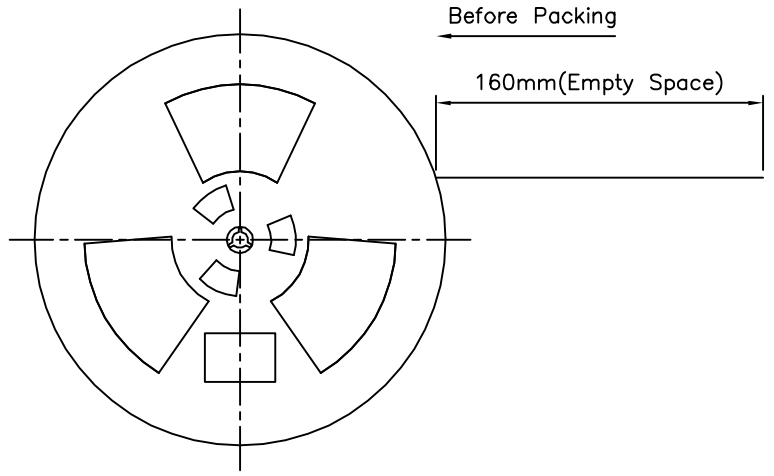

4UCON 元化興業股份有限公司
 4UCON TECHNOLOGY INC.

DRAWING No.		APPROVED BY		UNLESS OTHERWISE SPECIFIED TOLERANCES ARE .X ±0.3 X. ±0.3 ANG. ±2°
18901		EMILY		
		CHECKED BY		
		HZF		
		DRAWING BY		
		GAO		
SCALE	NONE	REV.	BO	UNIT
				mm

NO.	REV.	REVISIONS	CHK	DATE
△ BO		NEW RELEASE	HZF	01/15/2013