

SPECIFICATION
 Current:0.5A/Pin
 Voltage:50V AC/Pin
 Withstanding Voltage:300V AC Min. For 1 Minute
 Insulator Resistance:500 Megaohms Min.
 Contact Resistance:Initial:55 Milliohms Max./Pin
 Final:20 Milliohms Max.
 Operating Temperature:-40°C~+80°C
 Housing:LCP(UL94V-0),Black
 Contact:Phosphor Bronze,Gold Plated On Contact Area,
 Gold Flash On Solder Tails,Over Nickel
 Fitting Nail:Brass,Tin Plated On Solder Area,Over Nickel
 RoHS Compliant

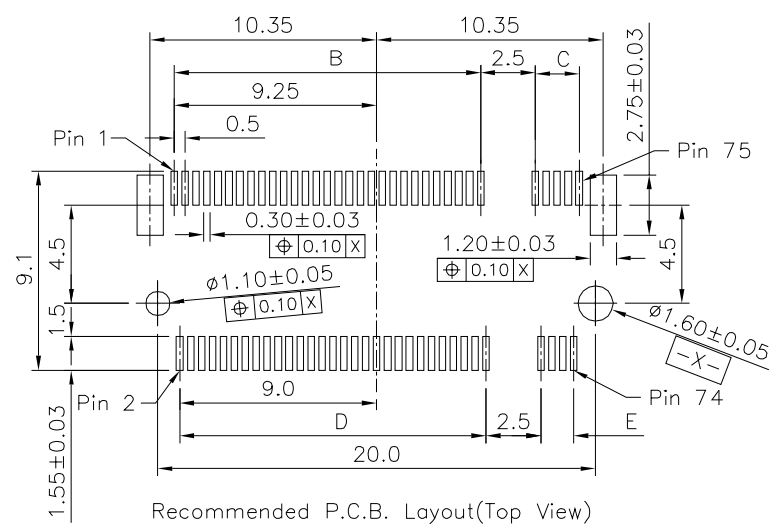
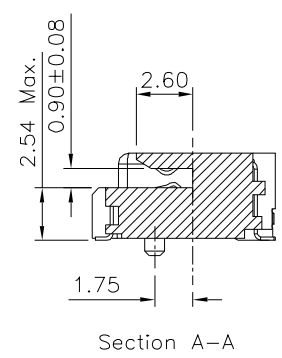
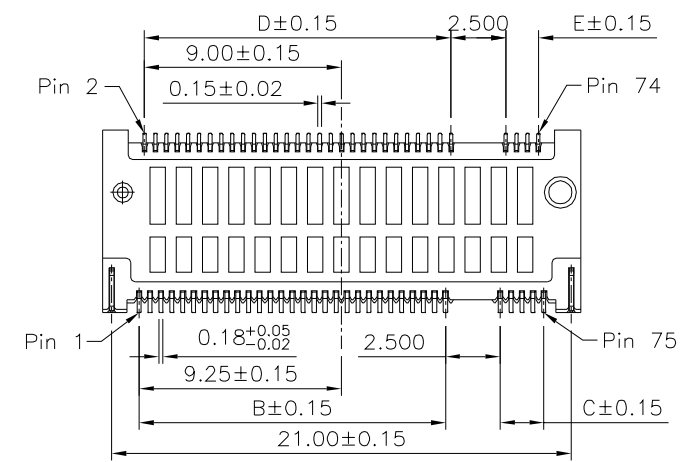
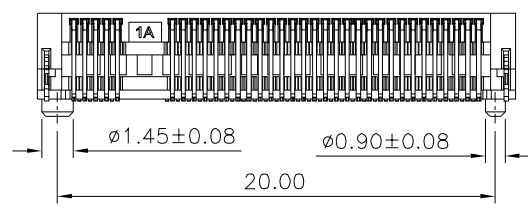
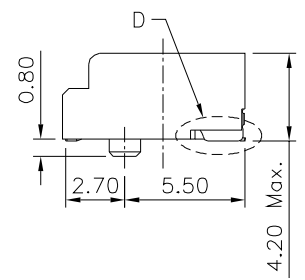
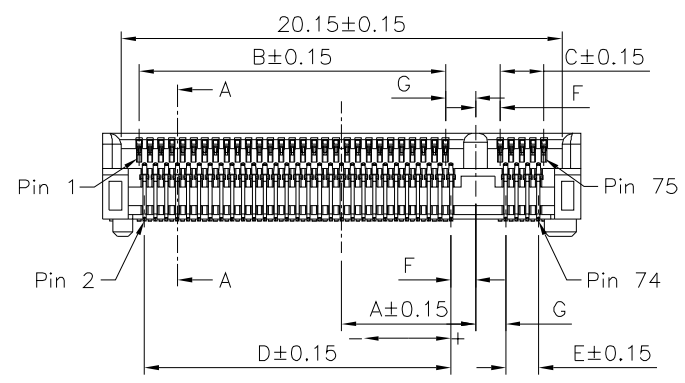

4UCON 元化興業股份有限公司
 4UCON TECHNOLOGY INC.

DRAWING No.		APPROVED BY		UNLESS OTHERWISE SPECIFIED TOLERANCES ARE X. ±0.40 .X ±0.30 .XX ±0.20 .XXX ±0.10
22759		MEI		
		CHECKED BY	HZF	
		DRAWING BY	LSM	
SCALE	NONE	REV.	A0	UNIT mm

AO	NEW RELEASE	HZF	03/14/2024
NO. REV.	REVISIONS	CHK	DATE

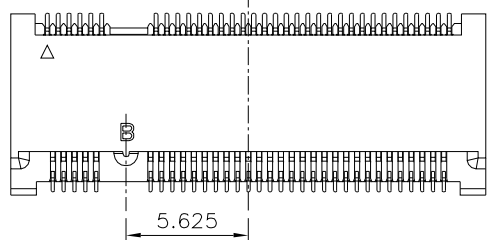

B TYPE

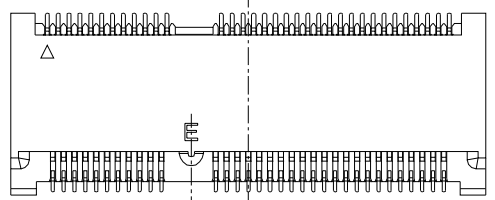

E TYPE

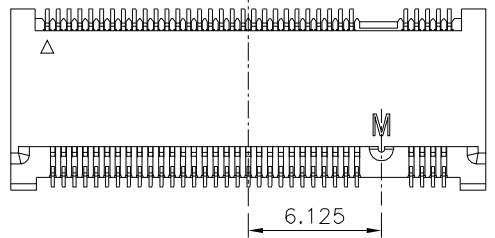

M TYPE

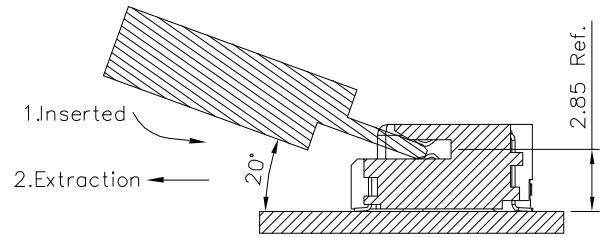
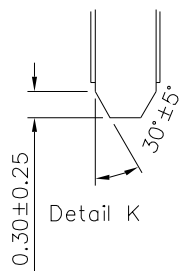
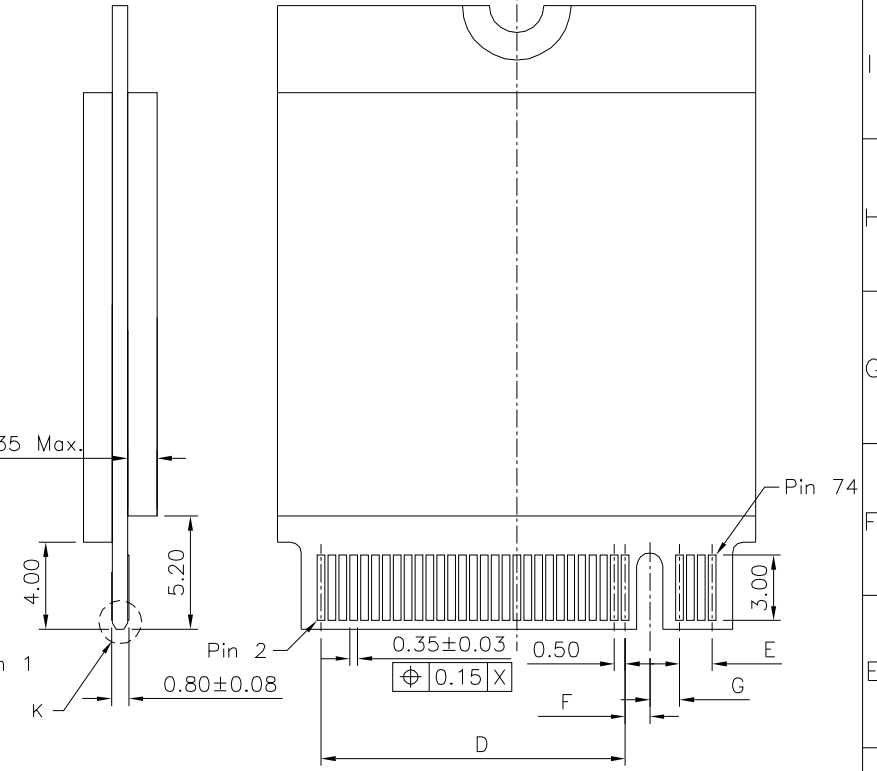
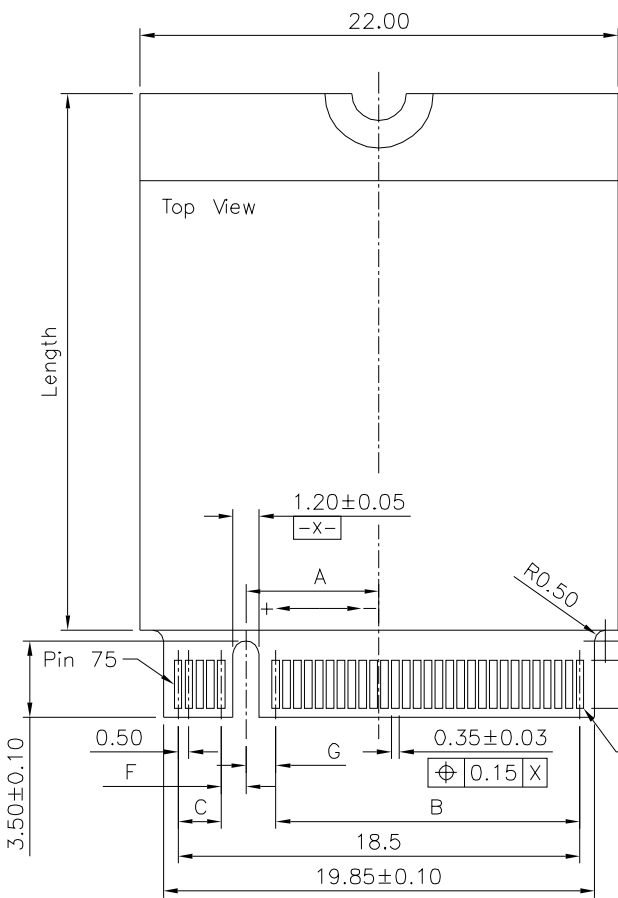

Recommended Operating Flow:
Mate:1
Unmate:2

Key ID	A	B	C	D	E	F	G
B	-5.625	2.5	13.5	2.0	13.5	1.375	1.125
E	-2.625	5.5	10.5	5.0	10.5	1.375	1.125
M	6.125	14.0	2.0	14.0	1.5	1.125	1.375

4UCON 元化興業股份有限公司
4UCON TECHNOLOGY INC.

DRAWING No. 22759

SCALE NONE

REV. A0

APPROVED BY MEI

CHECKED BY HZF

DRAWING BY LSM

UNLESS OTHERWISE SPECIFIED TOLERANCES ARE

X. ±0.40

.X ±0.30

.XX ±0.20

.XXX ±0.10

NO.	REV.	REVISIONS	CHK	DATE
△ A0		NEW RELEASE	HZF	03/14/2024